

TM

TM

TM

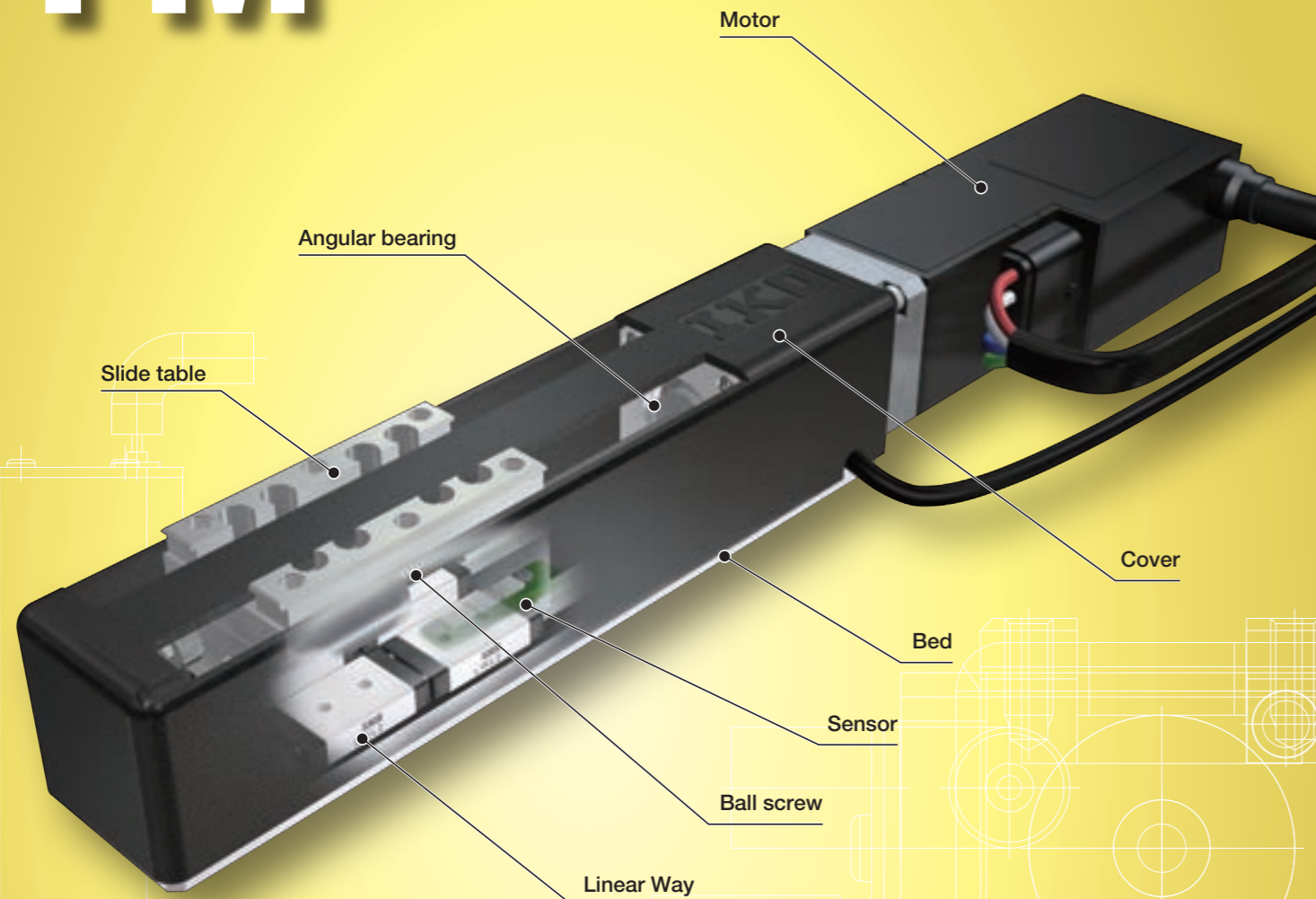
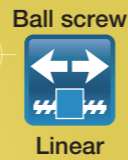

Points

● **Ground ball screw drive realizes ultra-small positioning table with sectional height of 20mm and width of 17mm.**

1 Incorporating a Micro Linear Way L of 2mm in rail width in the table guiding parts and a miniature ball screw of 2mm in diameter in the feeding mechanism, this is an unparalleled ultra-small size positioning table with ground ball screw drive type.

● **Table specification is selectable according to your use.**

3 There are two types in the shape of slide table: standard table and long table. As two Micro Linear Way L with two slide units are incorporated in parallel into the long table, the table is structurally resistant to moment and complex load. The motor can be selected from two types of AC servomotor (standard type or high torque type) and stepper motor according to your use.

● **Maximum table speed of 75mm/s is exerted.**

2 Combination of high-lead ball screws and high-torque AC servomotors enables the table to move at high speed without reducing the accuracy.

● **Super small sensor can also be optionally built in.**

4 Built-in origin, pre-origin, CW limit and CCW limit sensors can be indicated without modifying the outside dimensions.

☑ **Widely applicable in such fields as below!**

Featuring the ultra-small size yet super precision positioning capability, this table is best suited to enhancing the accuracy of the positioning mechanism of super small device. And, use of stainless steel in steel parts allows the table to be used even in a location where use of oil and grease should be preferably avoided and under the environment that tends to suffer from water scattering.

Best suited for positioning mechanism of super small device!

- Measuring equipment
- Watch assembling machine
- Medical equipment
- Winder etc....
- Electronic parts assembling machine
- Bio-related equipment
- Robot

☑ **This table can respond to various requests!**

We can prepare tables of various specifications such as switching table specification, lead screw specification, and stainless steel cover specification, in order to meet customer needs. For more information, please contact IKO.

Example of special specification: Switching table specification

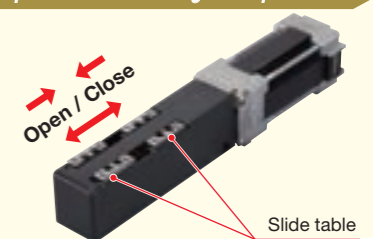

Major product specifications

Driving method	Precision ball screw
Linear motion rolling guide	Linear Way (ball type)
Built-in lubrication part	No built-in
Material of table and bed	Stainless steel
Sensor	Select by identification number

Accuracy

unit: mm

Positioning repeatability	±0.001~0.002
Positioning accuracy	0.015
Lost motion	-
Parallelism in table motion A	-
Parallelism in table motion B	-
Attitude accuracy	-
Straightness	-
Backlash	-

Variation

Shape	Model and size	Stroke length (mm)					
		10	20	30	40	50	60
 Standard table	TM15	-	☆	-	☆	-	☆
	TM15G	☆	-	☆	-	☆	-

Identification Number

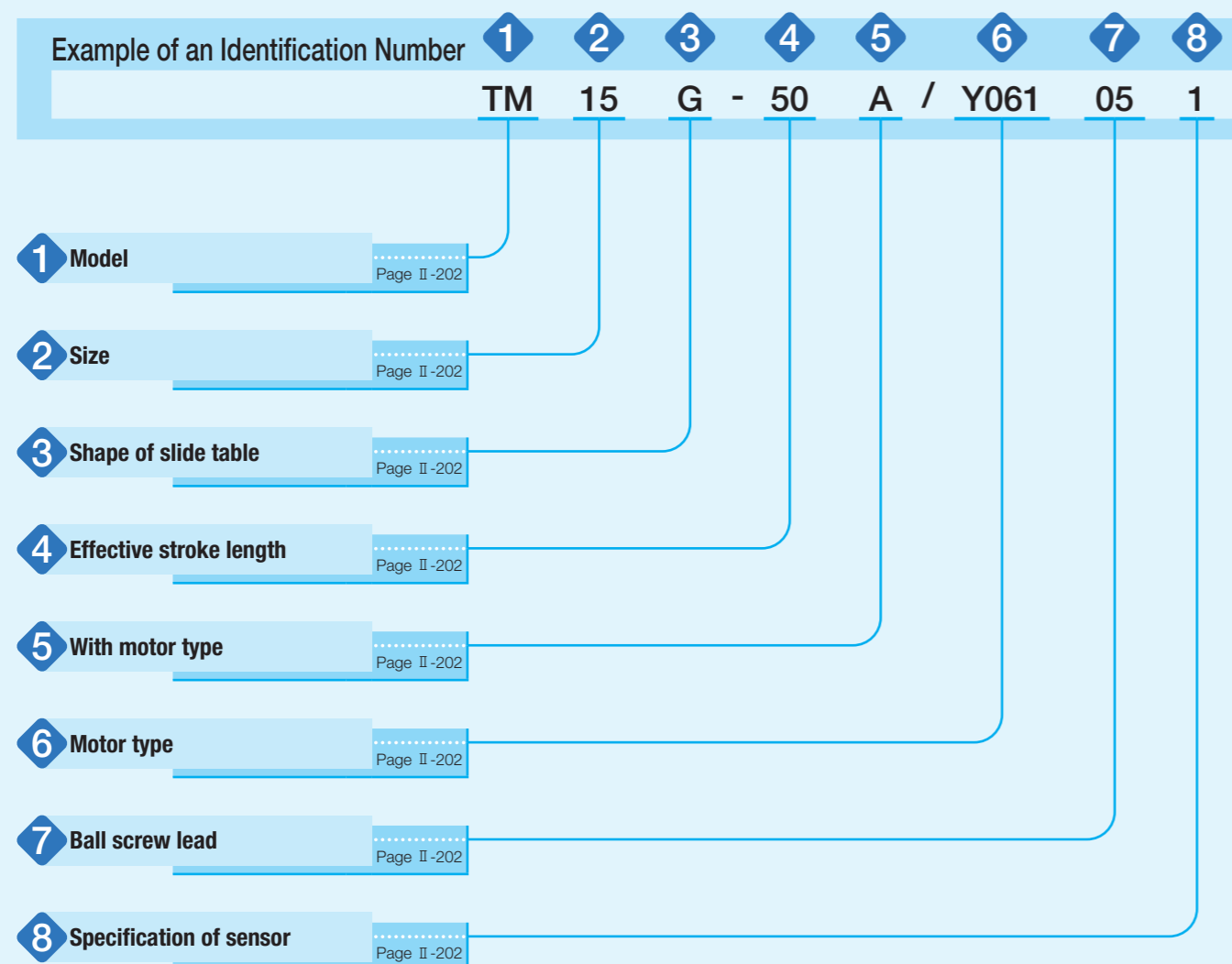

Identification Number and Specification

- 1 Model: TM: Micro Precision Positioning Table TM
- 2 Size: 15: Table width 15mm
- 3 Shape of slide table: No symbol: Standard table G: Long table
- 4 Effective stroke length: Select a effective stroke length from the list of Table 1.

Table 1 Shape of slide table and effective stroke length

Shape of slide table	Effective stroke length mm
Standard table	20, 40, 60
Long table	10, 30, 50

- 5 With motor type: A: With motor
- 6 Motor type: Y061: AC servomotor (standard type)
Y062: AC servomotor (high torque type)
V001: Stepper motor (five phases)
When Y062 is specified, Ball screw lead of 0.5mm cannot be specified.
For details of motor specification, see pages II-195 and II-197.
If you use a non-standard motor, please contact IKO.
- 7 Ball screw lead: 05: Lead 0.5mm
10: Lead 1.0mm
15: Lead 1.5mm
When the ball screw lead of 0.5mm is specified, Y062: AC servomotor (high torque type) cannot be specified in 6.
- 8 Specification of sensor: 0: Without sensor
1: With sensor (on the right as viewed from the side opposite the motor)
2: With sensor (on the left as viewed from the side opposite the motor)
Once you select "Without sensor", adding a sensor afterward is not allowed.
Once you select "Without sensor", the motor wiring will be on the right as viewed from the side opposite the motor.
If "With sensor" is selected, the directions of wirings for the motor and the sensor are the same direction.

Remark: A resin table cover is used but a stainless table cover can also be manufactured. If needed, please contact IKO.

Specifications

Table 2 Accuracy

unit: mm

Model	Ball screw lead	Positioning repeatability	Positioning accuracy
TM15 -20	0.5	±0.001	0.015
	1	±0.002	
	1.5		
TM15 -40	0.5	±0.001	0.015
	1	±0.002	
	1.5		
TM15 -60	0.5	±0.001	0.015
	1	±0.002	
	1.5		
TM15G-10	0.5	±0.001	0.015
	1	±0.002	
	1.5		
TM15G-30	0.5	±0.001	0.015
	1	±0.002	
	1.5		
TM15G-50	0.5	±0.001	0.015
	1	±0.002	
	1.5		

Table 3 Maximum speed

Motor type	Number of revolutions of motor min ⁻¹	Maximum speed mm/s		
		Lead 0.5mm	Lead 1mm	Lead 1.5mm
AC servo motor	3 000	25	50	75
Stepper motor	1 800	15	30	45

Remark: To measure the practical maximum speed, it is required to consider operation patterns based on the motor to be used and load conditions.

Table 4 Maximum carrying mass

Model and size	Ball screw lead mm	Length of slide table	Carrying mass position mm	Maximum carrying mass kg								
				Length L	Horizontal direction				Vertical direction			
					0	100	200	300	0	100	200	300
TM15	0.5	Standard	0	0.7	0.4	0.2	0.1	0.7	0.1	-	-	
			100	0.7	0.4	0.2	0.1	0.1	-	-	-	
			200	0.7	0.4	0.2	0.1	-	-	-	-	
			300	0.7	0.4	0.2	0.1	-	-	-	-	
			0	0.7	0.3	0.1	0.1	0.7	0.1	-	-	
			100	0.7	0.3	0.1	0.1	0.1	-	-	-	
	1	Standard	200	0.7	0.3	0.1	0.1	-	-	-	-	
			300	0.7	0.2	0.1	0.1	-	-	-	-	
			0	0.7	0.2	0.1	-	0.7	0.1	-	-	
			100	0.7	0.2	0.1	-	-	-	-	-	
			200	0.7	0.2	0.1	-	-	-	-	-	
			300	0.7	0.2	0.1	-	-	-	-	-	
TM15G	0.5	Long	0	1.5	0.8	0.4	0.2	0.7	0.7	0.7	0.4	
			100	1.5	0.8	0.4	0.2	0.7	0.7	0.5	0.4	
			200	1.5	0.8	0.4	0.2	0.6	0.4	0.4	0.3	
			300	1.5	0.8	0.4	0.2	0.4	0.3	0.3	0.2	
			0	1.5	0.6	0.3	0.2	0.7	0.7	0.5	0.3	
			100	1.5	0.6	0.3	0.2	0.7	0.6	0.4	0.3	
	1	Long	200	1.5	0.6	0.3	0.2	0.4	0.3	0.3	0.2	
			300	1.5	0.6	0.3	0.2	0.3	0.2	0.2	0.2	
			0	1.5	0.5	0.3	0.2	0.7	0.7	0.5	0.3	
			100	1.5	0.5	0.3	0.2	0.7	0.5	0.3	0.2	
			200	1.5	0.5	0.3	0.2	0.4	0.3	0.2	0.2	
			300	1.5	0.5	0.3	0.2	0.2	0.2	0.2	0.1	
1.5	Long	0	1.5	0.5	0.3	0.2	0.7	0.7	0.5	0.3		
		100	1.5	0.5	0.3	0.2	0.7	0.5	0.3	0.2		
		200	1.5	0.5	0.3	0.2	0.4	0.3	0.2	0.2		
		300	1.5	0.5	0.3	0.2	0.2	0.2	0.2	0.1		

Remark: The maximum carrying mass is adjusted by the mass when the rating life of the linear motion rolling guide, ball screws, or bearings is 18,000 hours during continuous operation at a number of revolutions of the motor of 3000min⁻¹ and an acceleration/deceleration time of 0.2s. The mass calculated is based upon the basic static load rating of the linear motion rolling guide.

Table 5 Maximum load mass

Model and size	Ball screw lead mm	Maximum load mass kg	
		Horizontal direction	Vertical direction
TM15	0.5	85	20
	1	47	10
	1.5	32	7
TM15G	0.5	85	20
	1	47	10
	1.5	32	7

Remarks 1. The maximum load mass shows the mass that ensures acceleration/deceleration of 0.3G.

2. The values shown in this table were calculated with the motor with the highest rated torque installed, selected from the AC servomotor models listed in Table 11.

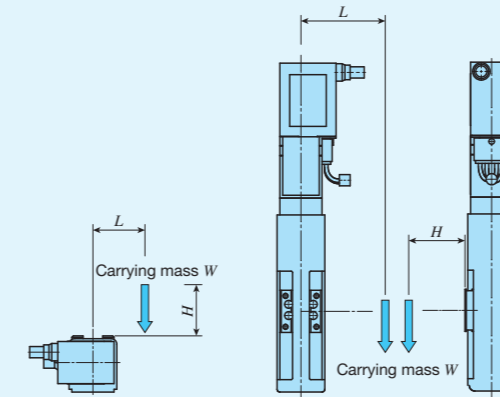

Carrying mass position (horizontal direction)

Carrying mass position (vertical direction)

Table 6 Specifications of ball screw

unit: mm

Model and size	Shape of slide table	Stroke	Shaft dia.	Overall length
TM15	Standard	20	2	54
		40		74
		60		94
	Long	10		54
		30		74
		50		94

Table 7 Table inertia, coupling inertia, and starting torque

Model and size	Table inertia J_T $\times 10^{-5} \text{kg} \cdot \text{m}^2$			Coupling inertia J_C $\times 10^{-5} \text{kg} \cdot \text{m}^2$	Starting torque T_s N·m
	Lead 0.5mm	Lead 1mm	Lead 1.5mm		
TM15 -20	0.00013	0.00016	0.00022	0.0028	0.005
TM15 -40	0.00016	0.00019	0.00024		
TM15 -60	0.00018	0.00021	0.00026		
TM15G-10	0.00014	0.00019	0.00028		
TM15G-30	0.00016	0.00021	0.00030		
TM15G-50	0.00018	0.00023	0.00032		

Mounting

For the processing accuracy of the Precision Positioning Table mounting surface and the tightening torque of the fixing screws, see page III-30.

Sensor Specification

Table 8 Sensor timing chart

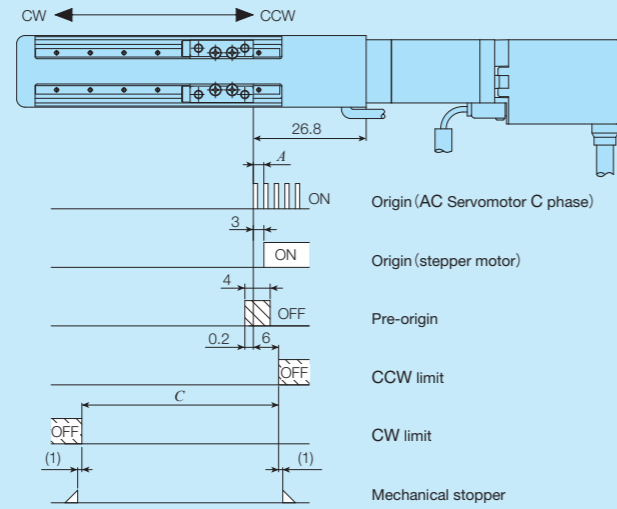

unit: mm

Model and size	Ball screw lead	A	Effective stroke length ⁽¹⁾	C (Ref.)
TM15 -20	0.5	0.5	20	Effective stroke length+2
	1	1		
	1.5	1.5		
TM15 -40	0.5	0.5	40	Effective stroke length+2
	1	1		
	1.5	1.5		
TM15 -60	0.5	0.5	60	Effective stroke length+2
	1	1		
	1.5	1.5		
TM15G-10	0.5	0.5	10	Effective stroke length+0.5
	1	1		
	1.5	1.5		
TM15G-30	0.5	0.5	30	Effective stroke length+0.5
	1	1		
	1.5	1.5		
TM15G-50	0.5	0.5	50	Effective stroke length+0.5
	1	1		
	1.5	1.5		

Note (1) The sensor position cannot be adjusted. The effective stroke length indicates the stroke length that can be surely secured between the limit sensors.

- Remarks 1. "With sensor" or "Without sensor", and wiring directions are specified using the corresponding identification number.
 2. For the specifications of respective sensors, please see the section of sensor specification in General Explanation.
 3. The origin sensor is for stepper motor.

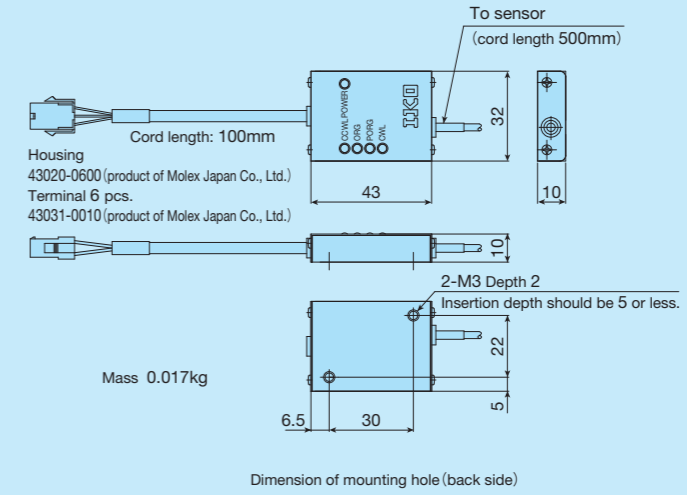
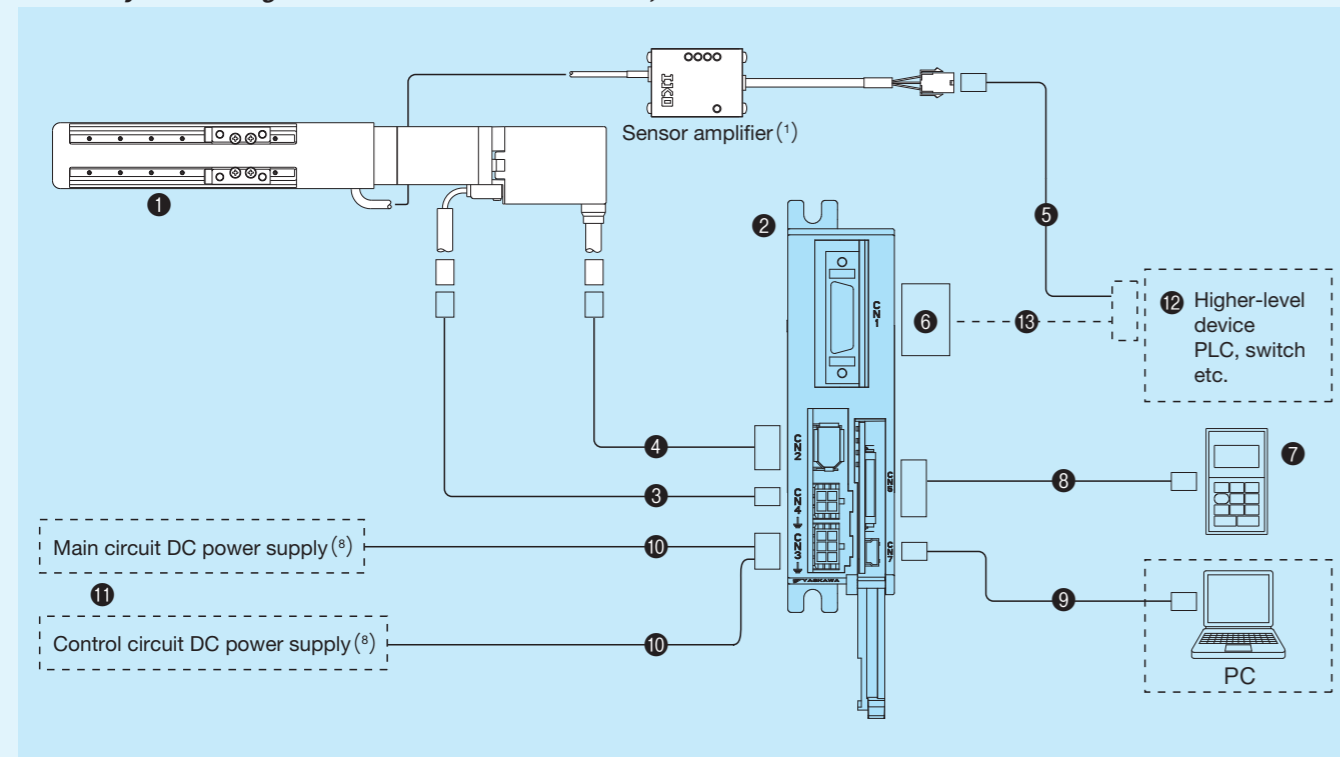

Fig.1 Outside dimension of sensor amplifier

System Configuration

A dedicated driver for Micro Precision Positioning Table TM is provided. Pages II-207 and II-208 show its typical system configuration. For the specifications of the driver, please see the section of specifications of motor and driver on pages II-209 to II-212. When you place an order, please specify desired identification numbers from the list of Tables 9 and 10.

Table 9 System Configuration for AC Servomotor (Y061, Y062)



No.	Name	Identification number	
1	Table body (motor code)	Y061 AC Servomotor (standard type)	Y062 AC Servomotor (high torque type)
2	Driver ⁽²⁾	SGDV-1R7EP1A	
3	Motor cord (3m) ^{(2) (3)}	JZSP-CF1M20-03-E	
4	Encoder cord (3m) ^{(2) (3)}	JZSP-CMP10-03-E	
5	Sensor extension cord (3m) ^{(2) (4) (5)}	TAE10W0-LC03	
6	I/O connector	TAE20W1-CN ⁽⁶⁾	
7	Digital operator ^{(2) (7)}	JUSP-OP05A-1-E	
8	Digital operator extension cable ^{(2) (7)}	JZSP-CF1S00-A3-E	
9	PC connection cable ^{(2) (7)}	JZSP-CVS06-02-E	
10	Power supply cable ^{(2) (4) (8)}	JZSP-CF1G00-□□-E	
11	Power supply ⁽⁹⁾		
12	Higher-level device	This must be prepared by customer.	
13	I/O connector connection cable		

- Notes (1) Once you select "Without sensor", a sensor amplifier will not be attached.
 (2) Manufactured by Yaskawa Electric Corporation.
 (3) For specific cord length, please contact IKO.
 (4) The higher-level device side of the cord will be loose.
 (5) If an origin signal is not required, do not use the origin sensor signal (ORG).
 (6) I/O connector TAE20W1-CN is a combined product of 10126-3000PE (connector) and 10326-52F0-008 (cover) from 3M Japan Limited.
 (7) A digital operator or ordinary PC is required for parameter setting.
 (8) Specify the length 1 - 3m in 1m increments in □□ of the identification number. (Example for 3m: JZSP-CF1G00-03-E)
 (9) The main circuit power supply supports DC48V as well as DC24V. The control circuit power supply is DC24V. Each power supply must be prepared separately by the customer.

Remarks 1: The motor cord, encoder cord and sensor extension cord have excellent bending resistance.
 2: Initial setting of parameters is required for the driver for AC Servomotor.
 When setting parameters with an ordinary PC, download the setting software from the Yaskawa Electric Corporation website.
 (URL: <http://www.e-mechatronics.com/download/tool/servo/sgmwinpls/download.html>)

Table 10 System Configuration for stepper motor (V001)

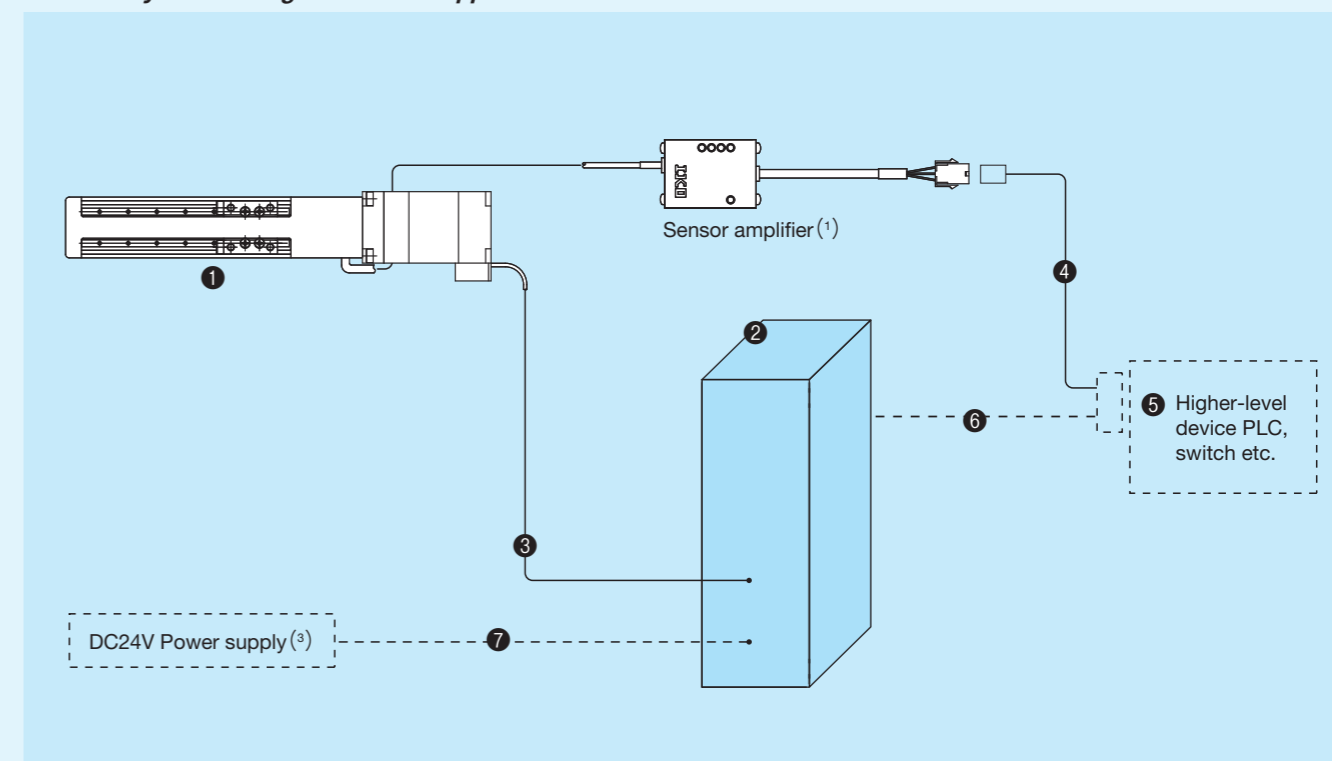

No.	Name	Identification number
1	Table body (motor code)	Stepper motor (five phases)
2	Driver ⁽²⁾	CVD503-K
3	Motor cord	TAE20R6-SM0□ (Fixed cable specification)
		TAE20R7-SN0□ (Bending-resistant cable specification)
4	Sensor extension cord ^{(4) (5)}	TAE10W0-LC03
5	Higher-level device	This must be prepared by customer.
6	I/O connector connection cord	This must be prepared by customer. ^{(6) (7)}
7	Power cord	This must be prepared by customer. ^{(6) (7)}

- Notes (1) Once you select "Without sensor", a sensor amplifier will not be attached.
 (2) Manufactured by Oriental Motor Co., Ltd.
 (3) DC24V power supply must be prepared separately by the customer.
 (4) For specific cord length, please contact IKO.
 (5) The higher-level device side of the cord will be loose.
 (6) Connectors are provided for the driver. Please see the section of specifications of motor and driver on page II-212.
 (7) Connect the cord directly.
 Remark The motor cord length can be specified using the box (□) at the end of the identification number, up to 5m in increments of 1m.
 (For 5m: TAE20R6-SM05)

Specifications of Motor and Driver

AC Servomotor manufactured by Yaskawa Electric Corporation (Y061, Y062)

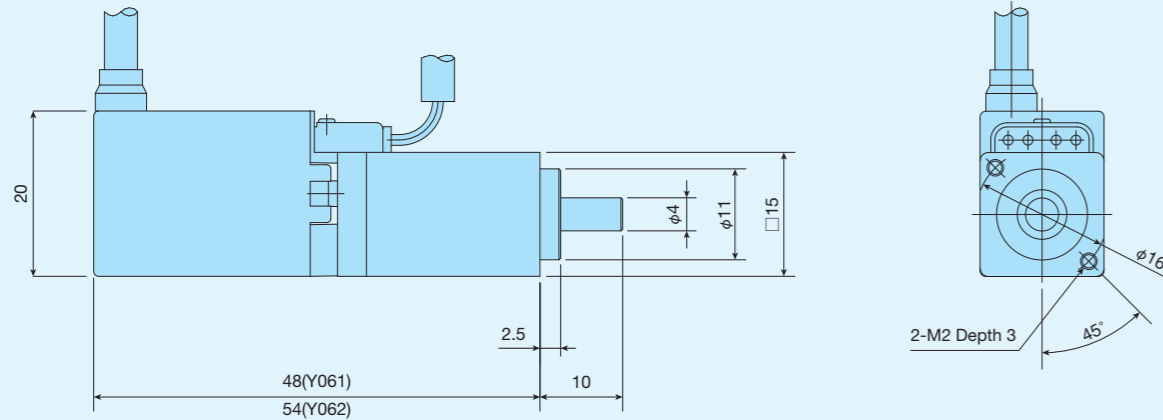

Table 11 Motor specifications

Motor type	Motor code	Motor identification number	Voltage specification	Rated output W	Rated torque N·m	Max. momentary torque N·m	Rated number of revolutions r/min	Motor inertia $J_M \times 10^{-4} \text{ kg} \cdot \text{m}^2$	Encoder resolution pulse/rev	Mass kg
Standard	Y061	SGMMV-B3E2A21	DC24V DC48V	3.3	0.0105	0.0263	3 000	0.000441	131072 (17bit)	0.055
High torque	Y062	SGMMV-B5E2A21	DC24V DC48V	5.5	0.0175	0.0438	3 000	0.000796	131072 (17bit)	0.06

Remarks 1. The main circuit power supply supports DC48V as well as DC24V.
2. Motor torque starts to decrease when the number of revolutions of the motor exceeds 3,000 min⁻¹.

Table 12 Specifications of wirings for the motor and connector

Motor code Y061,Y062			Motor side	Mating side
Pin No.	Content	Wire color		
1	U phase	Red	Connector 43020-0401 Contact 43031-0001 Molex Japan Co., Ltd.	Connector 43025-0400 Contact 43030-0001 Molex Japan Co., Ltd.
2	V phase	White		
3	W phase	Blue		
4	FG	Green		

Table 13 Specifications of wirings for the encoder and connector

Motor code Y061,Y062			Motor side	Mating side
Pin No.	Content	Wire color		
1	PG 5V	Orange	Socket connector solder type 54280-0609 Molex Japan Co., Ltd.	Connector crimp type 55100-0670 Molex Japan Co., Ltd.
2	PG 0V	Light green		
3	BAT(+)	Red/pink		
4	BAT(-)	Black/pink		
5	PS	Red/sky blue		
6	/PS	Black/sky blue		
Shell	FG	FG		

Table 14 Driver for AC Servomotor Y061/Y062, manufactured by Yaskawa Electric Corporation

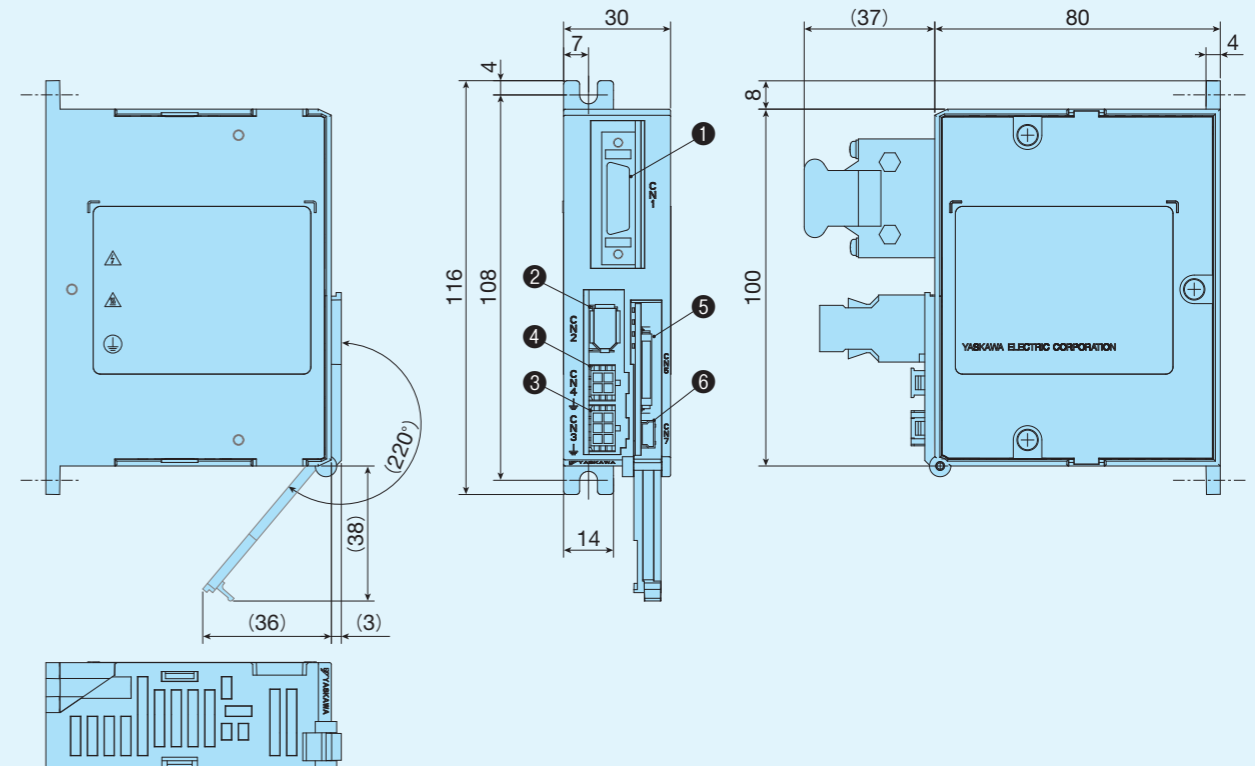

No.	Name	Function
①	CN1 I/O connector	Connect a pulse cord to this connector.
②	CN2 Encoder connector	Connect the encoder cord.
③	CN3 Driving power supply connector	Connect to the driving power supply.
④	CN4 Motor connector	Connect a motor cord to this connector.
⑤	CN5 Connector for digital operator	Connect the digital operator extension cable.
⑥	CN7 Connector for PC	Connect the PC connection cable.

Table 15 Driver specification

Identification number of driver	SGDV-1R7EP1A ⁽¹⁾	
Applicable motor code	Y061	Y062
Rated output of applicable motor	3.3W	5.5W
Feedback	Serial encoder 17bit	
Specified system of pulse input ⁽¹⁾	CW/CCW signal, pulse signal/rotational direction signal	
Specified method of pulse input ⁽¹⁾	Line driver, open collector	
Main circuit power supply voltage ⁽²⁾	DC24V±15%, DC48V±15%	
Control circuit power supply	DC24V±15%	
Continuous output current Arms	1.7	
Maximum output current Arms	4.1	
Operating temperature range	0~55°C	
Storage temperature range	-20~85°C	
Operating humidity	90% RH or lower (keep freeze/condensation free)	
Mass kg	0.3	

Note (1) This driver is a pulse train command type. If the network communication command type or analog voltage command type is required, please contact IKO.

(2) The main circuit power supply supports DC48V and DC24V.

Stepper motor (V001) manufactured by Oriental Motor Co., Ltd.

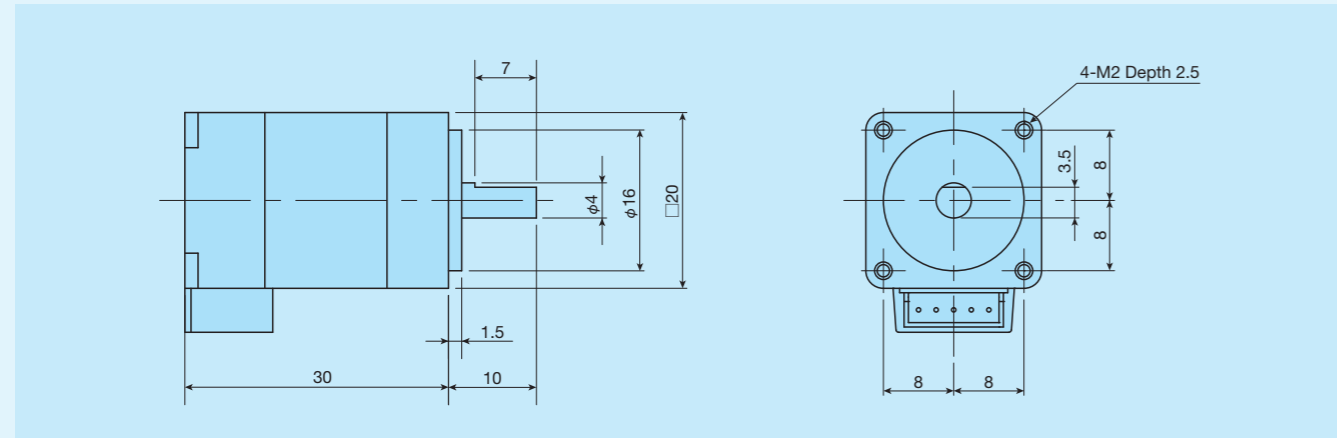

Table 16 Motor specifications

Motor code	Model number of motor	Step angle	Maximum holding torque N · m	Current A/phase	Rotor inertia J_M × 10 ⁻⁴ kg · m ²	Mass (Ref.) kg
V001	PK513PA	0.72	0.023	0.35	0.0016	0.05

Table 17 Specifications of wirings for the motor and connector

Pin No.	Color of lead wire	Motor side	Mating side ⁽¹⁾
1	Blue	Housing 51065-0500	Housing 51103-0500
2	Red		
3	Orange		
4	Green	Terminal 50212-8100	Terminal 50351-8100
5	Black		

Note (1) Mating-side connector must be prepared by customer.
Remark: Connectors are manufactured by Molex Japan Co., Ltd.

Table 18 Stepper motor driver manufactured by Oriental Motor Co., Ltd. (RoHS Compliant)

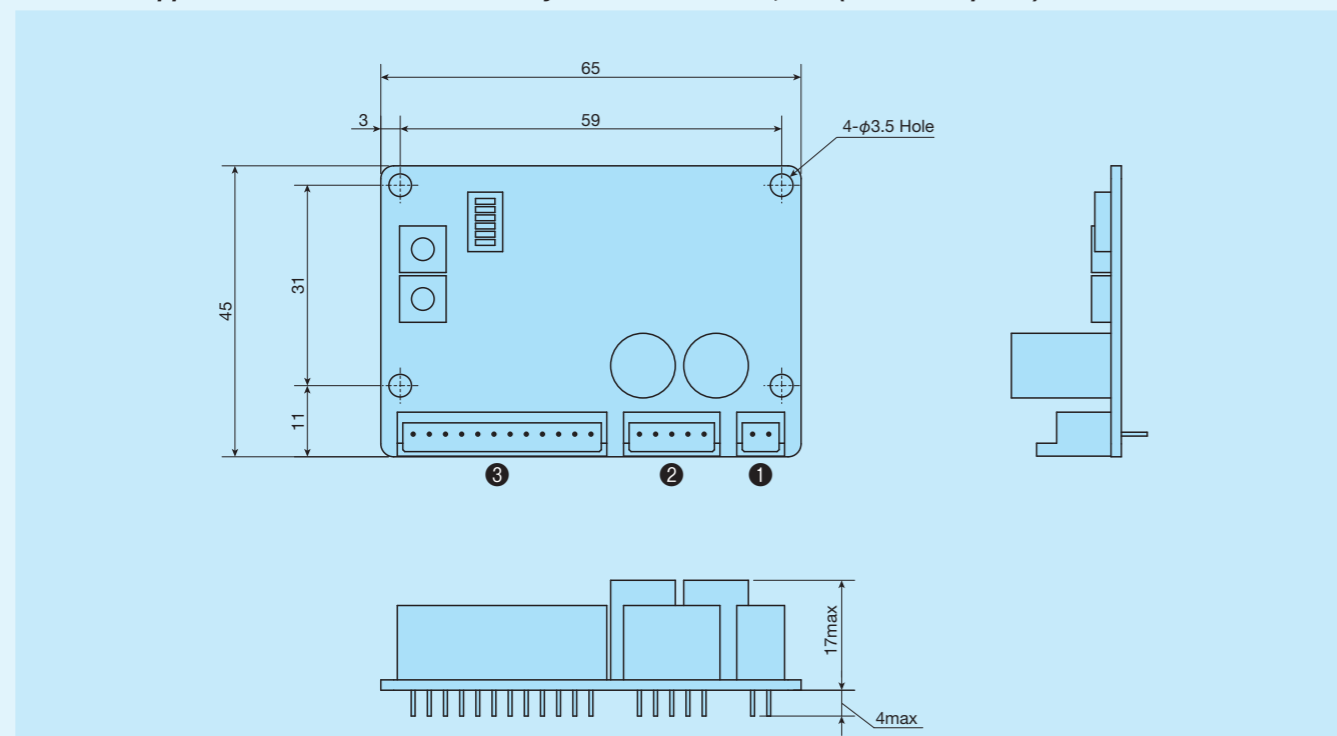

No.	Name	Function
①	CN1 Power supply connector	Connect a power supply to this connector.
②	CN2 Motor connector	Connect a motor cord to this connector.
③	CN3 Input/output signal connector	Connect a pulse cord to this connector.

Table 19 Stepper motor driver specifications

Identification number of driver	CVD503-K
Applicable motor code	V001
Driving method	Micro step drive bi-polar constant current method
Driver current (default settings)	0.35A/phase
Power supply voltage	DC24V ± 10%
Input current	0.6A
Maximum input pulse frequency	Higher-level controller line driver output: 1MHz (when duty is 50%) / Higher-level controller open collector output: 250kHz (when duty is 50%) negative logic pulse input
Ambient temperature (during operation)	0 to +50° C (keep freeze free)
Ambient humidity (during operation)	85% or lower (keep condensation free)
Atmosphere	Keep corrosive gas and dust free. Avoid direct contact with water, oil, etc.

Remark: DC24V is recommended for power supply voltage. The power supply must be prepared by customer.

Torque chart for stepper motor

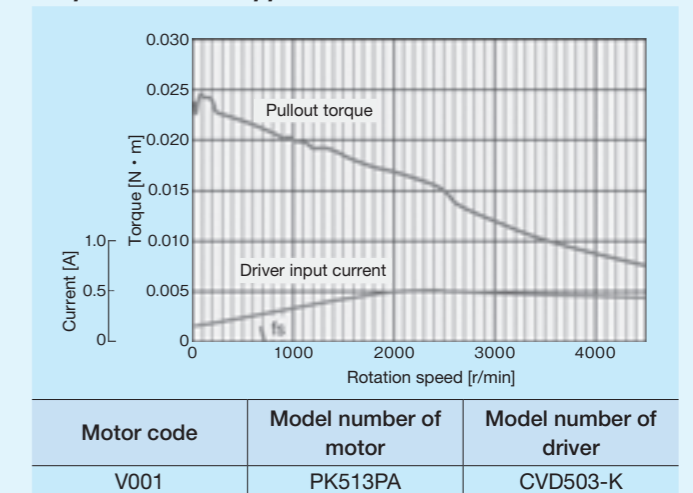
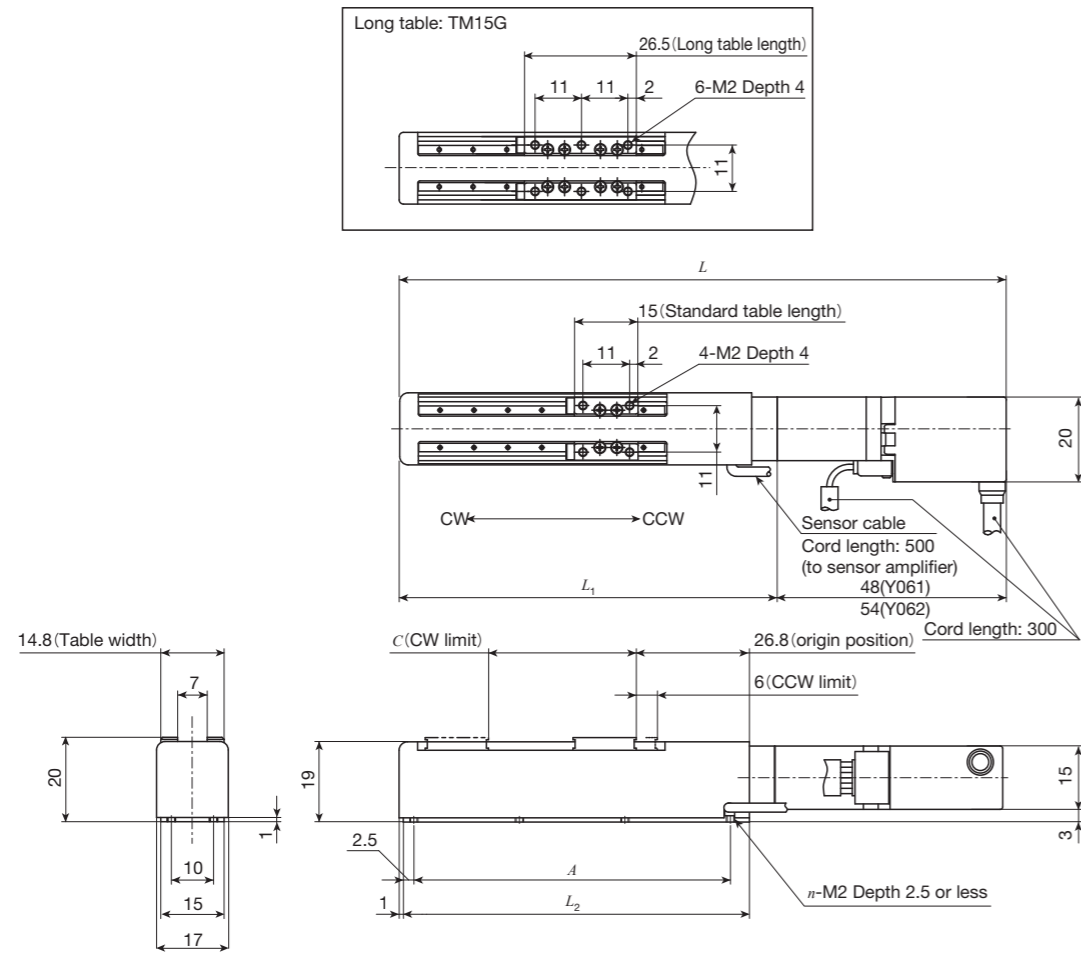

Table 20 Stepper motor driver accessories

Name	Model number		Remark
	Housing	Contact	
CN1 Power supply connector	51103-0200	50351-8100	Molex Japan Co., Ltd.
CN2 Motor connector	51103-0500		
CN3 Input/output signal connector	51103-1200		

IKO Micro Precision Positioning Table TM

TM15 Specifications of AC servomotor



Unit: mm

Model and size	Stroke length		Dimensions of table						Mass ⁽¹⁾ (Ref.) kg
	Effective stroke length ⁽²⁾	CW limit position C	Overall length L		L ₁	L ₂	Mounting holes of bed A (Number of units x pitch)		
			Y061	Y062			n		
TM15 -20	20	16	117	123	69	62	50 (2×25)	6	0.15
TM15 -40	40	36	137	143	89	82	75 (3×25)	8	0.16
TM15 -60	60	56	157	163	109	102	96 (4×24)	10	0.17
TM15G-10	10	4.5	117	123	69	62	50 (2×25)	6	0.16
TM15G-30	30	24.5	137	143	89	82	75 (3×25)	8	0.17
TM15G-50	50	44.5	157	163	109	102	96 (4×24)	10	0.18

Note ⁽¹⁾ Represents value when Y061 is specified. It will be 0.01 kg heavier when Y062 is specified.

⁽²⁾ The sensor position cannot be adjusted. The effective stroke length indicates the stroke length that can be surely secured between the limit sensors.

Remark: A resin table cover is used but a stainless steel table cover can also be manufactured. If needed, please contact IKO.

TM15 Specifications of stepper motor

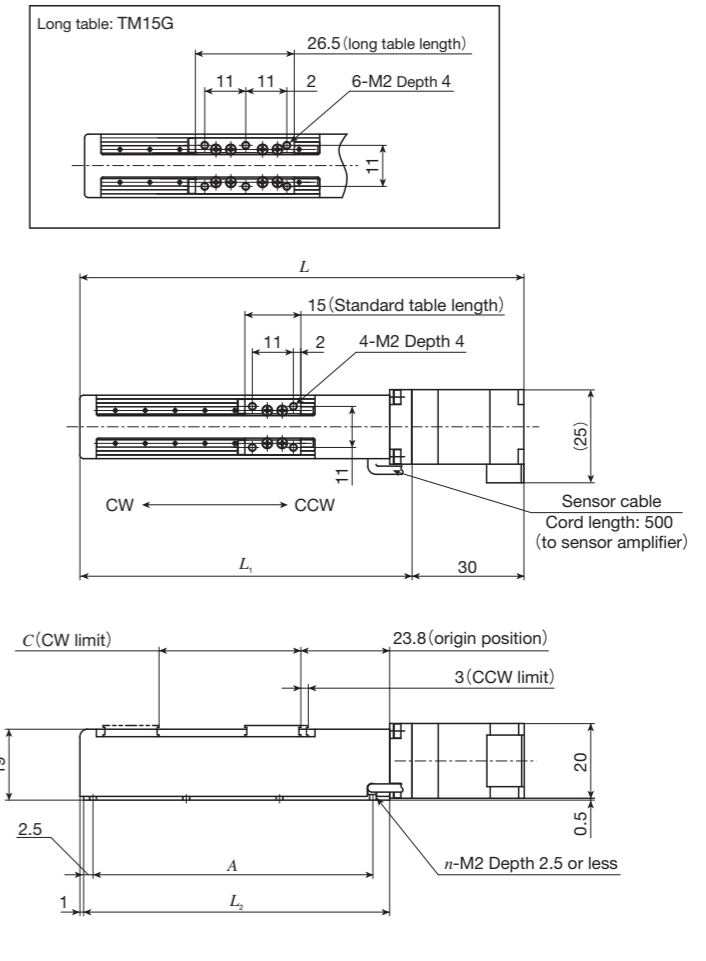

unit: mm

Model and size	Stroke length		Dimensions of table						Mass (Ref.) kg
	Effective stroke length ⁽¹⁾	CW limit position C	Overall length L		L ₁	L ₂	Mounting holes of bed A (the number of holes×pitch)		
			L ₁	L ₂			n		
TM15 -20	20	19	99	69	62	50 (2×25)	6	0.15	
TM15 -40	40	39	119	89	82	75 (3×25)	8	0.16	
TM15 -60	60	59	139	109	102	96 (4×24)	10	0.17	
TM15G-10	10	7.5	99	69	62	50 (2×25)	6	0.16	
TM15G-30	30	27.5	119	89	82	75 (3×25)	8	0.17	
TM15G-50	50	47.5	139	109	102	96 (4×24)	10	0.18	

Note ⁽¹⁾ The sensor position cannot be adjusted. The effective stroke length indicates the stroke length that can be surely secured between the limit sensors.

Remark: A resin table cover is used but a stainless table cover can also be manufactured. If needed, please contact IKO.